

# 3-phase motor driver and reversible motor driver

## BA6872AFM

The BA6872AFM has a 3-phase motor driver for VCR capstans, and a reversible motor driver for VCR loading. The capstan motor driver uses the three-phase, pseudo-linear drive method, and has a built-in torque ripple cancellation circuit, and an output transistor saturation prevention circuit. The loading motor driver has two logic inputs which are used to set the four operation modes (forward, reverse, stopped (idle) and brake).

### ●Applications

VCR capstan motors, VCR loading motors

### ●Features

- 1) 3-phase, pseudo-linear drive system.
- 2) Torque ripple cancellation circuit.
- 3) Output transistor saturation prevention circuit.
- 4) Hall element power supply.
- 5) Two control logic inputs set the four operation modes: forward, reverse, stopped (idle), and brake.
- 6) Output voltage setting is possible using the Vref pin.
- 7) Thermal shutdown (TSD) circuit.

### ●Absolute maximum ratings (Ta = 25°C)

Parameter	Symbol	Limits	Unit
Power supply voltage	Vcc	7	V
Power supply voltage	V <sub>M1</sub>	36	V
Power supply voltage	V <sub>M2</sub>	36	V
Power dissipation	P <sub>d</sub>	2200*1	mW
Operating temperature	T <sub>opr</sub>	-25~+75	°C
Storage temperature	T <sub>stg</sub>	-40~+150	°C
Output current (capstan)	I <sub>o peak1</sub>	1500*2	mA
Output current (loading)	I <sub>o peak2</sub>	700*2	mA
Hall element power supply current	I <sub>H peak</sub>	20	mA

\*1 When mounted on a 70mm×70mm×1.6mm glass epoxy board.

Reduced by 17.6mW for each increase in Ta of 1°C over 25°C.

\*2 Should not exceed P<sub>d</sub> or ASO values.

### ●Recommended operating conditions (Ta = 25°C)

Parameter	Symbol	Limits	Unit
Operating power supply voltage	Vcc	4~6	V
Operating power supply voltage	V <sub>M1</sub>	3~32*3	V
Operating power supply voltage	V <sub>M2</sub>	3~32*3	V
Hall signal input range	V <sub>HDC</sub>	1.5~(Vcc-1.8)	V

\*3 Should not exceed P<sub>d</sub> or ASO values.

● Block diagram

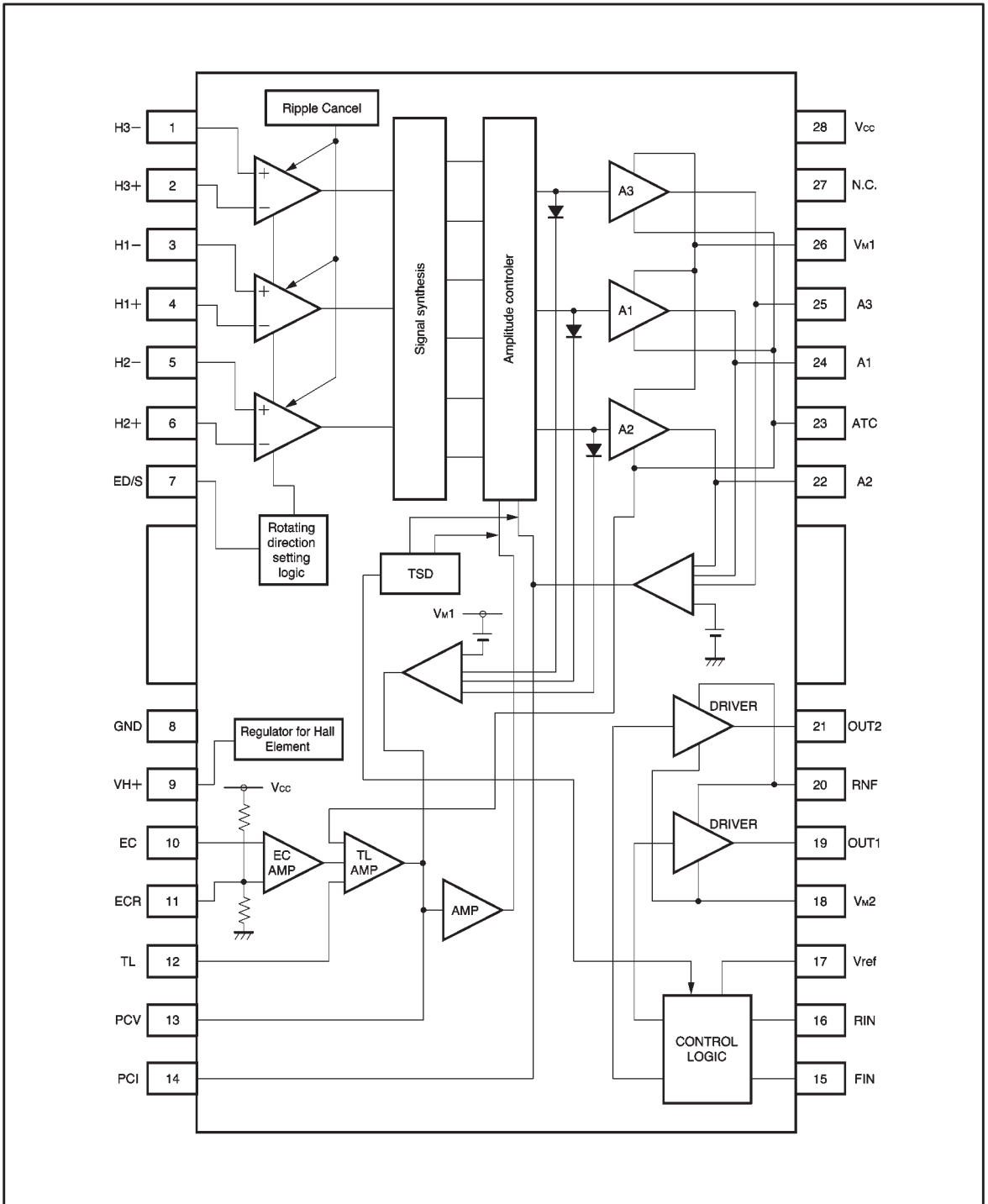

## ● Pin descriptions

Pin No.	Pin Name	Function
1	H3—	Hall signal input
2	H3+	Hall signal input
3	H1—	Hall signal input
4	H1+	Hall signal input
5	H2—	Hall signal input
6	H2+	Hall signal input
7	ED / S	Rotation direction setting input
8	GND	Signal GND
9	VH+	Hall element power supply
10	EC	Torque control voltage input
11	ECR	Torque reference voltage input
12	TL	Torque limit
13	PCV	Upper - side saturation prevention circuit phase compensation
14	PCI	Lower - side saturation prevention circuit phase compensation
15	FIN	Logic input
16	RIN	Logic input
17	Vref	Output high level voltage setting
18	V <sub>M2</sub>	Loading motor power supply
19	OUT1	Loading motor output
20	RNF	Loading motor GND
21	OUT2	Loading motor output
22	A2	Capstan motor output
23	ATC	Capstan motor GND (current detect pin)
24	A1	Capstan motor output
25	A3	Capstan motor output
26	V <sub>M1</sub>	Capstan motor power supply
27	N.C.	—
28	Vcc	Signal block power supply

\* Thermal dissipation FIN is internally connected to pin 8 (signal GND) .  
Handle FIN carefully.

● Input/output circuits

(1) Hall inputs (pins 1 to 6)

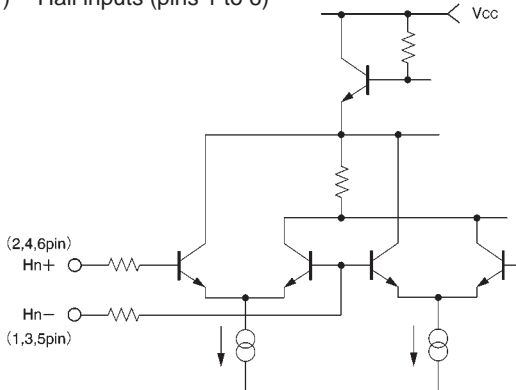

Fig.1

(2) Rotation direction setting input (pin 7)

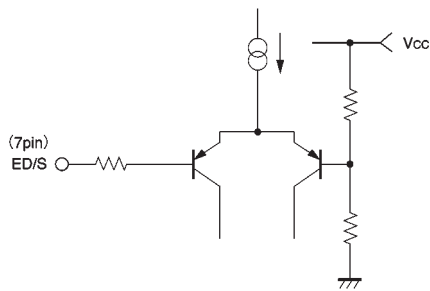

Fig.2

(3) Hall element power supply (pin 9)

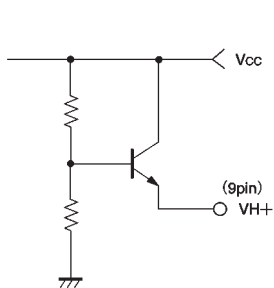

Fig.3

(4) Torque control input (pins 10 and 11)

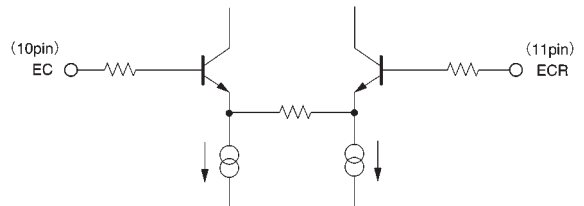

Fig.4

(5) Torque limit (pin 12)

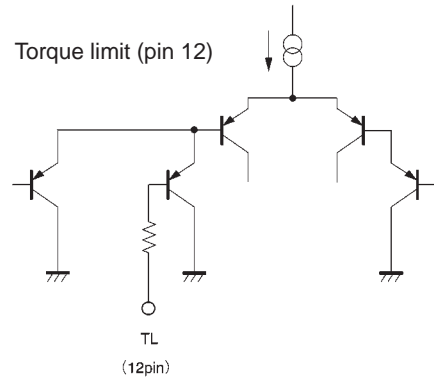

Fig.5

(6) Logic input (pins 15 and 16)

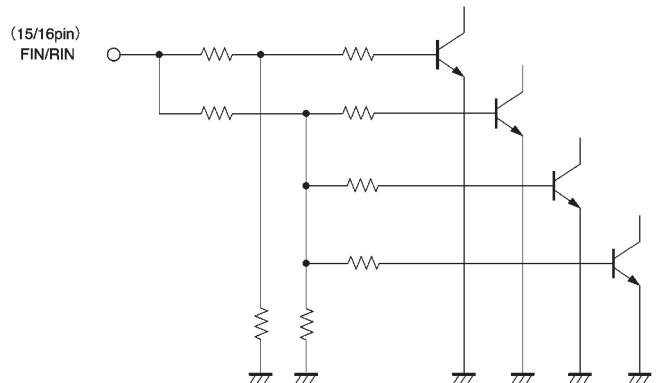

Fig.6

(7) Loading motor output (pins 17 to 21)

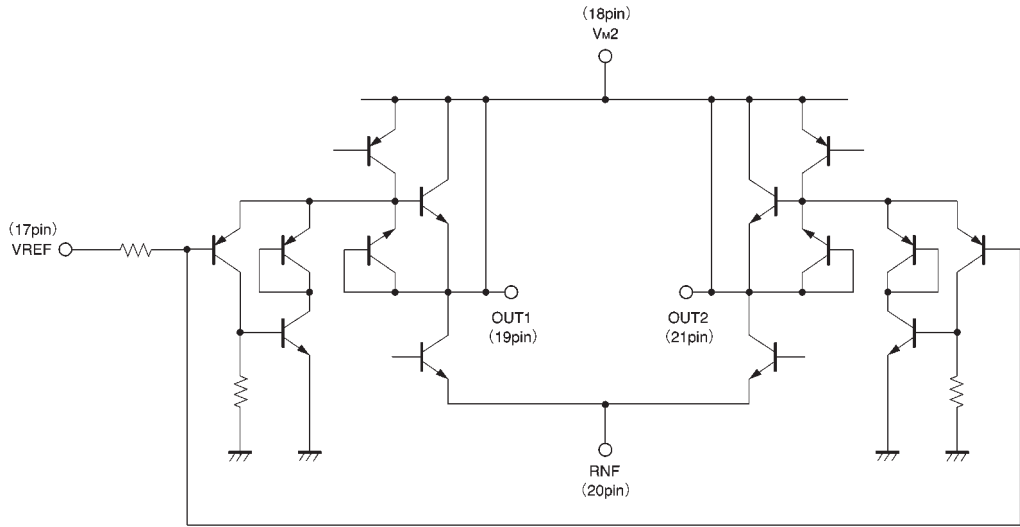

Fig.7

(8) Capstan motor output (pins 22 to 26)

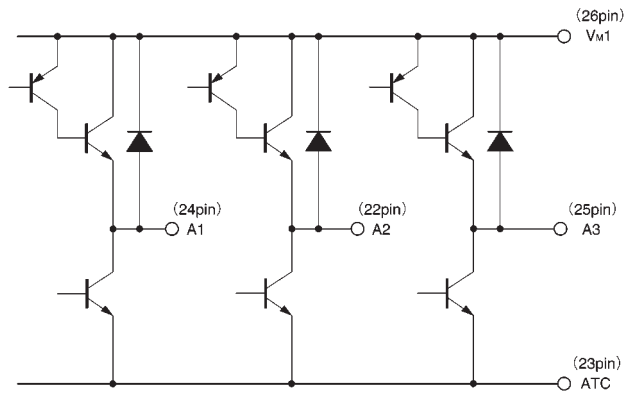

Fig.8

●Electrical characteristics (unless otherwise noted, Ta = 25°C, Vcc = 5V, Vm1 = 14V, Vm2 = 14V)

Parameter	Symbol	Min.	Typ.	Max.	Unit	Coniditions
Circuit current 1	Icc1	—	8	13	mA	EC=GND, Hall input LLH (FIN, RIN) = (L, L)
Circuit current 2	Icc2	—	12	19.5	mA	EC=GND, Hall input LLH (FIN, RIN) = (L, H), (H, L)
Circuit current 3	Icc3	—	14	22.5	mA	EC=GND, Hall input LLH (FIN, RIN) = (H, H)
〈Capstan block〉						
Hall input conversion offset	HEofs	−10	—	+10	mV	
Torque control offset	Ecofs	−120	—	+120	mV	
Output idle voltage	ECidle	—	—	10	mV	
Torque control input gain	Gio	0.29	0.32	0.35	—	EC=ECR +0.2V to ECR+0.3V Hall input LLH, RATC=0.5Ω
ECR bias voltage	VECR	2.0	2.2	2.4	V	
Forward rotating voltage	ED / F	—	—	2.2	V	
Reverse rotating voltage	ED / R	2.8	—	—	V	
Hall element power supply voltage	VH+	2.45	2.65	2.85	V	IH+=9mA
TL-ATC offset	TL-ATCofs	35	60	85	mV	TL=0.35V, RATC=0.5Ω
Ripple cancellation ratio	VRcc	8.2	10.5	12.8	%	Input=LHH to LHM A1 phase output current
Output high level voltage	VOH	0.9	1.35	1.75	V	Io=0.8A, RATC=0.5Ω
Output low level voltage	VOL	1.15	1.6	2.05	V	Io=0.8A, RATC=0.5Ω
〈Loading block〉						
Input high level voltage	VIH	3.0	—	—	V	
Input low level voltage	VIL	—	—	2.0	V	
Input high level current	IiH	—	215	315	μA	FIN, RIN=3.0V
Upper-side output saturation voltage	VCEH	—	1.0	1.35	V	Forward or reverse mode Io=0.2A
Lower -side output saturation voltage	VCEL	—	0.2	0.3	V	Forward or reverse brake mode Io=0.2A
Vref current	IREF	—	9	13	μA	Forward or reverse mode Vref=7V
VOUT−Vref offset	Vref ofs	Vref −100	Vref 200	Vref 500	mV	Vref =7V, Io=0.2A

©Not designed for radiation resistance.

● Circuit operation

Capstan three-phase motor driver

(1) Pseudo-linear output

The IC generates a trapezoidal (pseudo-linear) output current whose waveform phase is 30 degrees ahead of that of the Hall input voltage.

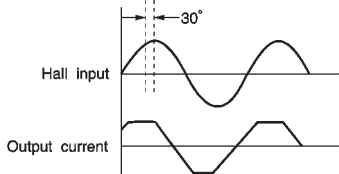

Fig.9

(2) Torque control

The output current can be controlled by adjusting the voltage applied to the torque control pins. The pins are the inputs to a differential amplifier, and the reference voltage side is biased with a voltage of 2.2V (Typ.).

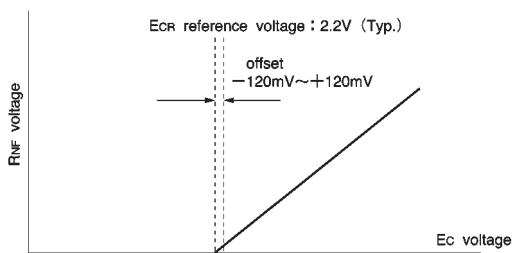

Fig.10

(3) Output current sensing and torque limiting

ATC (pin 23) is the output stage ground. Connect a small resistor (0.5Ω recommended) between this pin and the GND pin, and feedback the voltage drop across this resistor to the TL AMP input to detect the output current. The output current can be limited by adjusting the voltage applied to TL (pin 12). The current is limited when pin 12 reaches the same potential as pin 23. The output current under this condition is given by:

$$I_{MAX} = \frac{V_{TL} - (TL - ATC \text{ offset})}{R_{ATC}}$$

where  $R_{ATC}$  is the value of the resistor connected between the  $R_{ATC}$  pin and ground, and  $V_{TL}$  is the voltage applied to the TL pin.

(4) Motor direction control (ED/S pin)

The motor mode is forward when the ED/S is voltage is less than 2.2V, and reverse when the ED/S is voltage is greater than 2.8V.

(5) Output transistor saturation prevention circuit

This circuit monitors the output voltage and maintains the operation of the output transistors below their saturation levels. Operating the transistors in the linear characteristic range provides good control over a wide current range, and good torque characteristics even during overload.

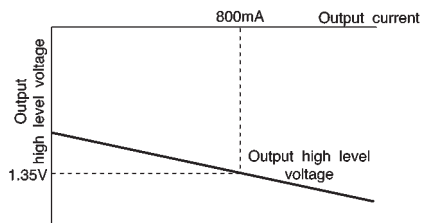

Fig.11

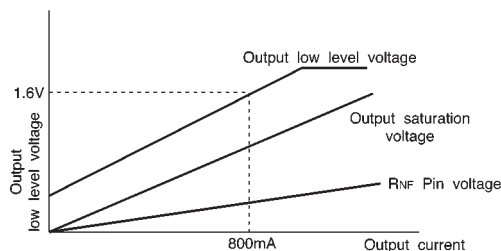

Fig.12

Reversible motor driver for loading

(6) Input block ( $F_{IN}$  and  $R_{IN}$ ) and mode explanation

These are the control signal input pins. The operations of the various modes are explained below. When  $F_{IN}$  is high level, and  $R_{IN}$  is low level, the mode is forward mode, and current flows from OUT1 to OUT2.

When  $F_{IN}$  is low level, and  $R_{IN}$  is high level, the mode is reverse mode, and current flows from OUT2 to OUT1.

When  $F_{IN}$  and  $R_{IN}$  are both high level, the mode is brake mode. In brake mode, the upper-side output transistor is off, and stops supply of current to the motor. The lower-side output transistor is on, and absorbs the back-rush of the motor and applies braking. When  $F_{IN}$  and  $R_{IN}$  are both low level, OUT1 and OUT2 are open-circuit potential, and the motor stops.

● Truth table

$F_{IN}$	$R_{IN}$	OUT1	OUT2	Mode
H	L	H	L	Forward mode
L	H	L	H	Reverse mode
H	H	L	L	Brake mode
L	L	OPEN	OPEN	Standby mode

(7)  $V_{ref}$  pin (output high voltage setting pin)

The output voltage can be varied by controlling  $V_{ref}$ .  
 $V_{OH} = V_{ref} + V_{BE}(\text{PNP}) - V_{BE}(\text{NPN}) + (V_{OUT} - V_{ref} \text{ off-set}) + I_{REF} \times R1$   
 However,  $V_{ref} \leq V_{M2} - [V_{sat}(\text{PNP}) + V_{BE}(\text{NPN})]$

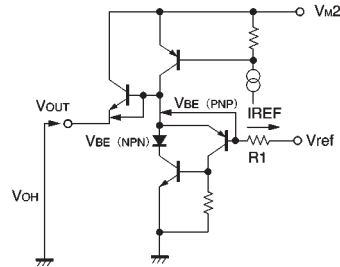

Fig.13

(8) Connection pins for output ground and output current sense resistor (RNF)

By connecting a resistor to this pin, it is possible to sense the amount of current flowing in the motor. By adding an electronic governor, and controlling  $V_{ref}$ , it is possible to construct a reversible motor driver.



●Application example

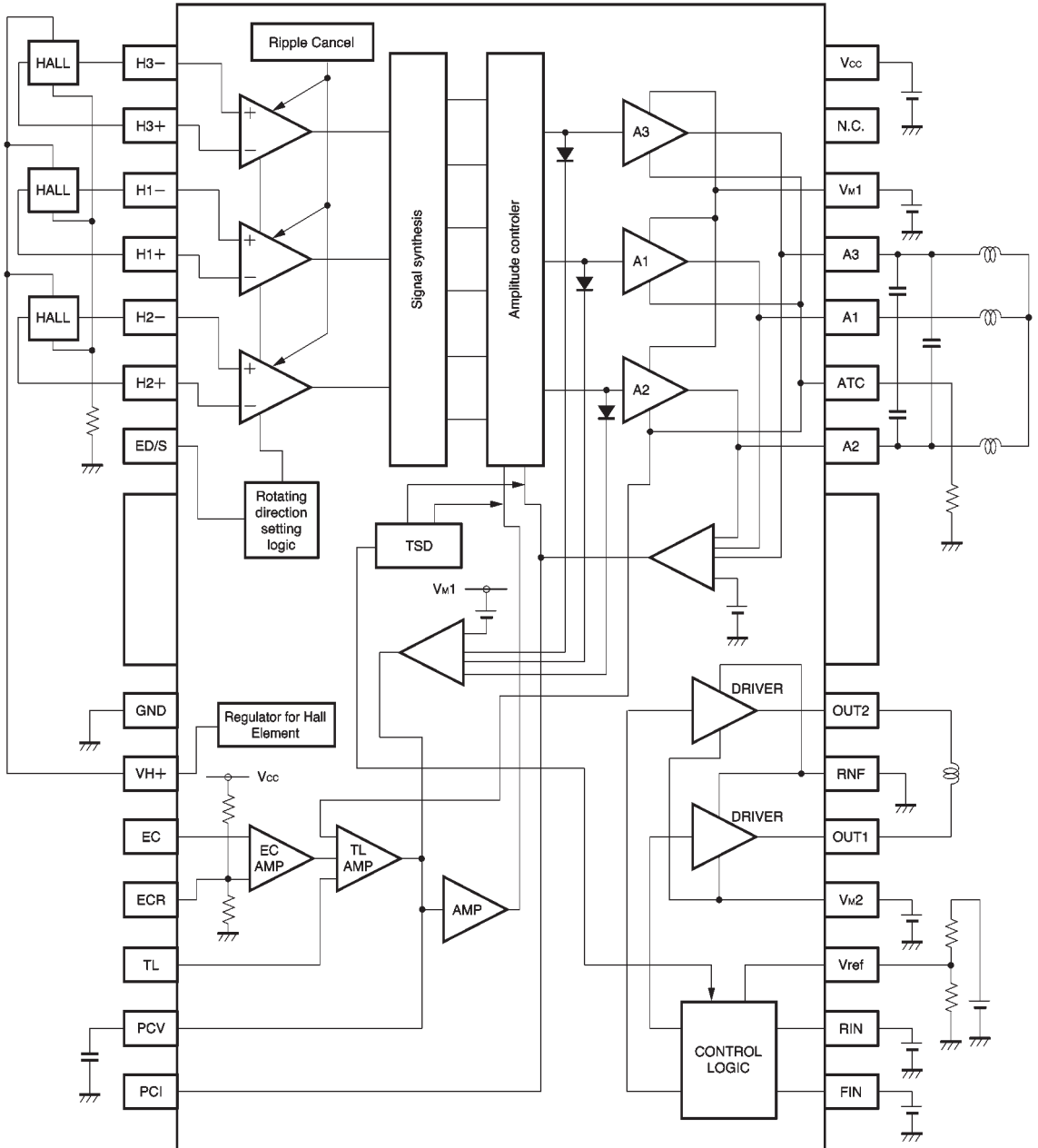

Fig.14

### ● Operation notes

#### (1) Thermal shutdown (TSD)

The BA6872AFM has a thermal shutdown circuit to protect the IC. The shutdown temperature is 175 °C (Typ.) and the hysteresis width is 65 °C (Typ.).

When the circuit is activated due to an increase in the chip temperature, the output pins (pins 5, 6, and 9) are set to the open state. This circuit is functional against excessive power dissipation, output short-circuiting, and other irregularities in the output current, but does not work against overheating caused by high internal currents due to externally-caused IC damage, or pin-to-pin shorting.

#### (2) Hall input

The Hall input circuit is shown in (1) on the I/O circuits. Hall devices can be connected either in series or in parallel. Be sure to keep the Hall input within the range 1.5V to ( $V_{CC} - 1.8V$ ).

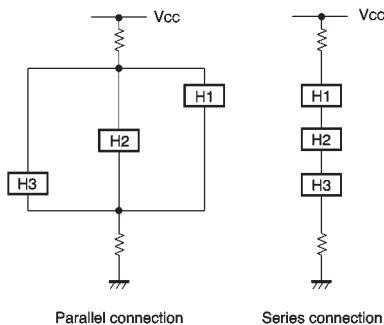

#### (3) Setting pin for the output high-level voltage ( $V_{ref}$ )

The voltage applied to the setting pin for the output high-level voltage should not exceed the  $V_{M2}$  voltage. Connect this to  $V_{M2}$  when not using it.

When the  $V_{ref}$  pin is connected to a low impedance circuit for voltage setting, there is a chance that the output voltage may oscillate.

When setting the voltage, set it via an impedance, or connect a capacitor between  $V_{ref}$  and GND.

The impedance and capacitor values will differ depending on the motor type, PCB pattern, and load current, so test the values using your actual circuit.

#### (4) GND

The GND (pin 8) potential must be kept below that of the other pins at all times. The thermal dissipation FIN is internally connected to pin 8. Take care regarding handling of FIN.

#### (5) Input pins

Do not apply voltage to the inputs when  $V_{CC}$  is not being supplied. Also, in the same way, even if  $V_{CC}$  is being supplied, the inputs must be either at or below the  $V_{CC}$  level.

#### (6) Back-rush voltage

The back-rush voltage will vary depending on the operating conditions, environment, and motor characteristics. Take care to ensure that the back-rush voltage does not interfere with the operation of the IC.

#### (7) Large current lines

Large currents flow in the power supply and GND lines of this IC. Therefore, depending on the PCB pattern layout and the values of external circuit components connected between the power supply and GND such as capacitors, this large current can be returned to the input, and cause incorrect operation and oscillation. To avoid this, carefully check the PCB layout and the values of all circuit components.

(8) The power dissipation of the IC depends on how it is mounted. Perform thermal design carefully.

#### (9) Power consumption

The power dissipated by the IC varies widely with the applied voltage and output current. Pay close attention to the allowed power dissipation, and base your thermal design on the thermal resistance data and transient thermal resistance data to ensure that the ratings are not exceeded.

#### (10) ASO

Make sure that the output current and supply voltage do not exceed the ASO values.

#### (11) Input mode switching

To improve reliability, when switching modes, first switch to the open mode.

(12) This IC is not equipped with a circuit to limit in-rush current. Therefore, connect a current limiting resistor to limit the in-rush current.

(13) Depending on the thermal dissipation conditions, power supply voltage, and type of motor, the potentials on the output pins of this IC can swing to levels well below GND, and cause faulty operation. In this case, take appropriate countermeasures such as connecting a diode between the outputs and GND.

(14) Great care has been paid to the quality of this component. However, if the absolute maximum ratings for temperature and applied voltage are exceeded, the IC may be destroyed. Since it is not possible to predict whether the IC will be in the short mode or open mode if it is destroyed, be sure to use sufficient physical protective measures (fuses etc.) if there is a chance that the maximum ratings of the IC will be exceeded.

● External dimensions (Units: mm)

