

System power supply for CD player-equipped audio systems

BA3950A

With 13.3V (external transistor required), 12V, 10V, and 5.6V outputs, the BA3950A power supply IC is best suited for CD player-equipped audio systems.

●Applications

CD player-equipped audio systems

●Features

- 1) 13.3V (external transistor required), 12V, 10V, and 5.6V outputs are built in (one output for each voltage).
- 2) Output current limit circuit protects the IC against short-circuiting damage.
- 3) Thermal protection circuit prevents heat damage to the IC.
- 4) Compact SIP-M12 package allows a large power dissipation.

●Absolute maximum ratings (Ta = 25°C)

Parameter	Symbol	Limits	Unit
Power supply voltage	V _{CC}	23	V
Power dissipation	P _d	3000*	mW
Operating temperature	T _{opr}	-25~+75	°C
Storage temperature	T _{stg}	-55~+150	°C

* Reduced by 24mW for each increase in Ta of 1°C over 25 °C.

●Recommended operating conditions (Ta = 25°C)

Parameter	Symbol	Min.	Typ.	Max.	Unit
Power supply voltage	V _{CC}	6.5	18	22	V

● Block diagram

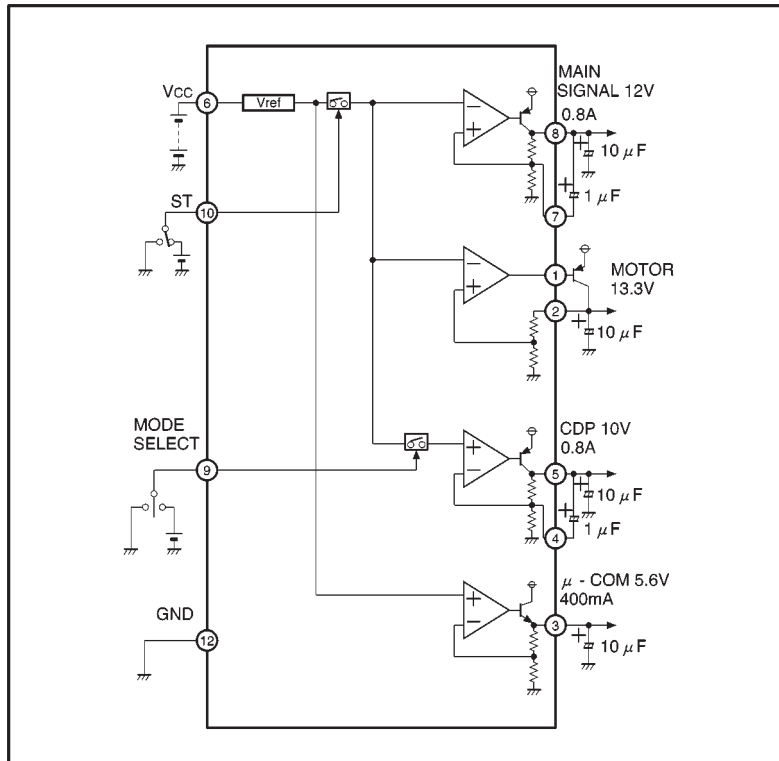

● Pin descriptions

Pin No.	Pin name	Function
1	MOTORB	Pin for external transistor base
2	MOTORC	Pin for external transistor collector
3	μ - COM	5.6V output
4	C1	Capacitor pin for improving the 10V output ripple rejection
5	CDP	10V output
6	V _{CC}	V _{CC} input
7	C2	Capacitor pin for improving the 12V output ripple rejection
8	MAIN	12V output
9	MODE	Mode switching
10	ST	Standby switching
11	N. C.	Not used
12	GND	GND

● Input / output circuits

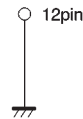
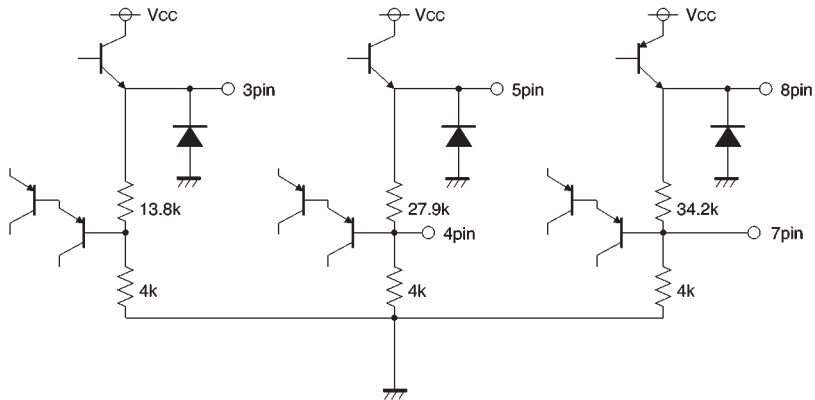
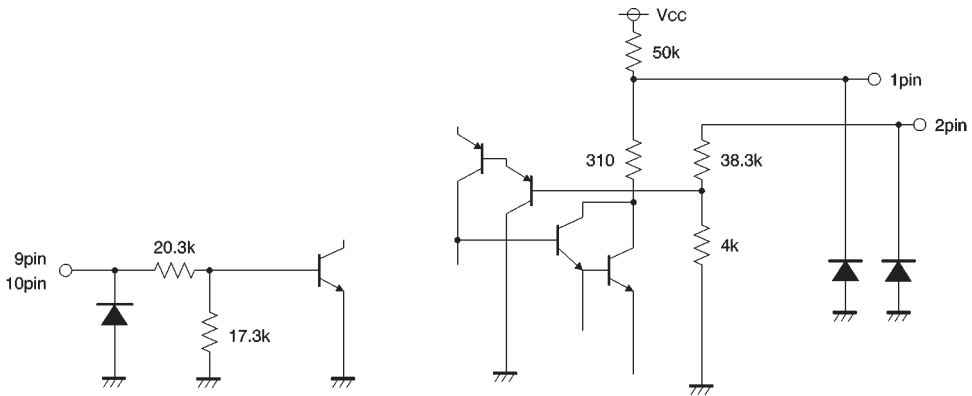

Units : R (Ω)

●Electrical characteristics (unless otherwise noted, Ta = 25°C and V_{CC} = 8V)

Parameter	Symbol	Min.	Typ.	Max.	Unit	Conditions
Standby supply current	I _{ST}	—	1.7	3.4	mA	V _{TH-S1} =0V
〈MOTOR section〉						
Output voltage	V _{OM}	12.6	13.3	14.0	V	Load current=550 mA, external transistor (2SB1185, F-rank)
Base current driving capacity	I _{OB}	10	—	—	mA	
〈MAIN SIGNAL section〉						
Output voltage	V _{O1}	11.4	12.0	12.6	V	I _{O1} =640mA
Voltage regulation	ΔV _{O11}	—	55	200	mV	I _{O1} =640mA
Load regulation	ΔV _{O12}	—	140	440	mV	I _{O1} =0~640mA
Minimum I/O voltage differential	ΔV _{O13}	—	0.5	1.0	V	I _{O1} =640mA
Output current capacity	I _{O1}	0.8	—	—	A	
Ripple rejection ratio	R. R11	45	56	—	dB	f=100Hz I _{O1} =640mA
* Ripple rejection ratio	R. R11	60	70	—	dB	f=100Hz I _{O1} =640mA *C2=1 μF
〈CDP section〉						
Output voltage	V _{O2}	9.5	10.0	10.5	V	I _{O2} =480mA
Voltage regulation	ΔV _{O21}	—	40	200	mV	I _{O2} =480mA
Load regulation	ΔV _{O22}	—	130	440	mV	I _{O2} =0~480mA
Minimum I/O voltage differential	ΔV _{O23}	—	0.5	1.0	V	I _{O2} =480mA
Output current capacity	I _{O2}	800	—	—	mA	
Ripple rejection ratio	R. R2	45	54	—	dB	f=100Hz I _{O2} =480mA
* Ripple rejection ratio	R. R2	60	70	—	dB	f=100Hz I _{O2} =480mA *C1=1 μF
〈μ-COM section〉						
Output voltage	V _{O3}	5.3	5.6	5.9	V	I _{O3} =200mA
Voltage regulation	ΔV _{O31}	—	25	200	mV	I _{O3} =200mA
Load regulation	ΔV _{O32}	—	40	200	mV	I _{O3} =0~200mA
Minimum I/O voltage differential	ΔV _{O33}	—	1.0	1.5	V	I _{O3} =200mA
Output current capacity	I _{O3}	400	—	—	mA	
Ripple rejection ratio	R. R3	50	60	—	dB	f=100Hz I _{O3} =200mA
〈Input section〉						
Voltage when standby OFF	V _{TH-S1}	—	—	1.0	V	MAIN SIGNAL, MOTOR OFF
Voltage when standby ON	V _{TH-S2}	1.8	—	—	V	MAIN SIGNAL, MOTOR ON
Input high level current	I _{ST}	140	240	340	μA	V _{TH-S2} =5V
〈MODE SW section〉						
Voltage when MODE OFF	V _{TH-m1}	—	—	1.0	V	CDP OFF when V _{TH-S2} is ON
Voltage when MODE ON	V _{TH-m2}	1.8	—	—	V	CDP ON when V _{TH-S2} is ON
Input high level current	I _m	140	240	340	μA	MODE=5V

* Asterisked ripple rejection ratio corresponds to the case where capacitors (1 μF) are used between pins 4 and 5 and between pins 7 and 8 to improve ripple rejection.

©Not designed for radiation resistance.

● Circuit operation

The MAIN, MOTOR, and μ -COM outputs rise when ST is 1.4V (Typ.).

The CDP output rises when MODE is 1.4V (Typ.) and ST is 1.4V (Typ.).

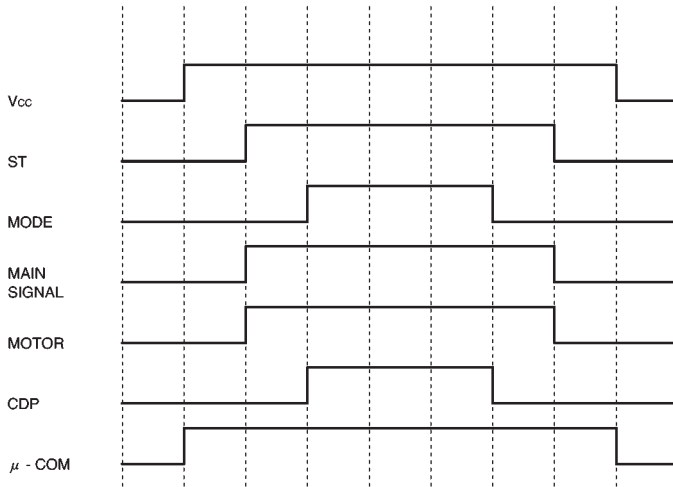

Fig.1 Timing chart

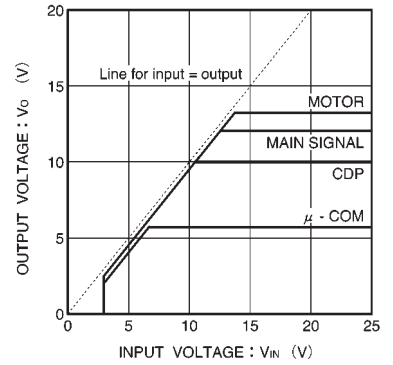

Fig.2 Input voltage vs. output voltage

● Application example

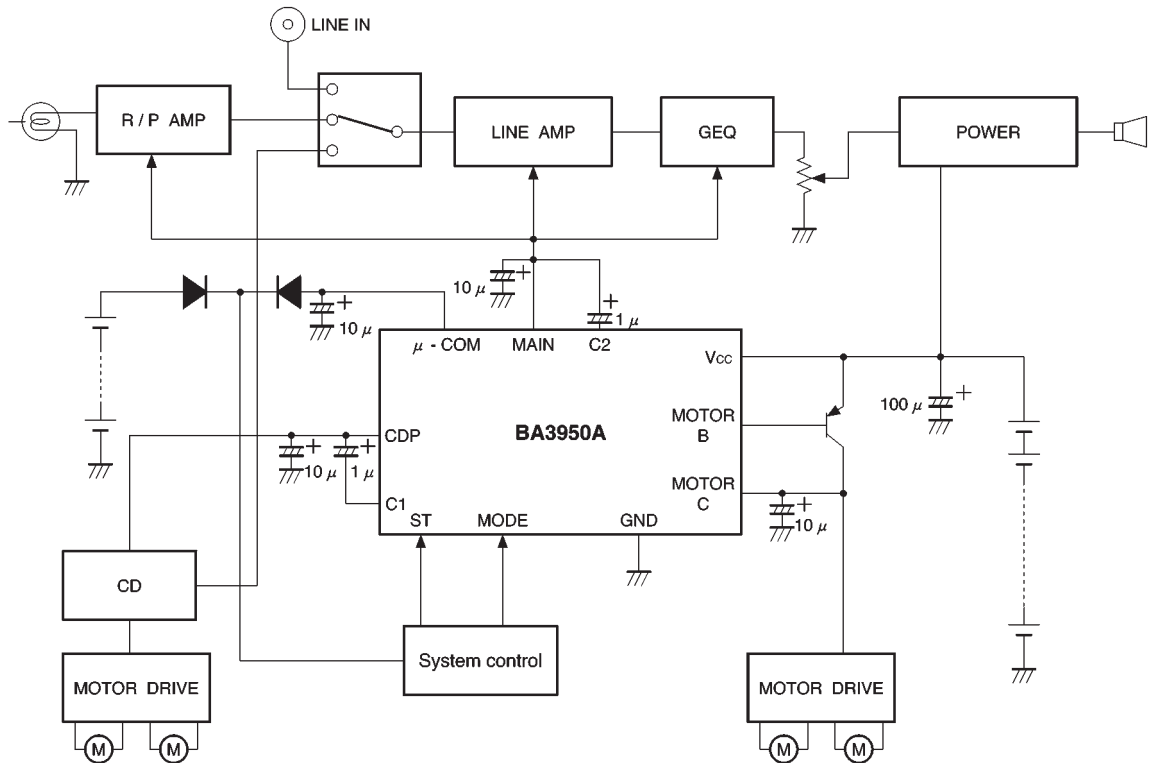

Fig.3

● Operation notes

(1) Operating power supply voltage

When operating within proper ranges of power supply voltage and ambient temperature, most circuit functions are guaranteed. Although the rated values of electrical characteristics cannot be absolutely guaranteed, characteristic values do not change drastically within the proper ranges.

(2) Power dissipation (Pd)

Refer to the heat reduction characteristics (Fig. 4) and the rough estimation of IC power dissipation given on a separate page. If power dissipation exceeds the allowable limit, the functionality of IC will be degraded (such as reduction of current capacity by increased chip temperature). Make sure to use the IC within the allowable range of power dissipation with a sufficient margin.

(3) Preventing oscillation at each output

To stop oscillation of output, make sure to connect a capacitor having a value $1\mu\text{F}$ or greater between GND and each output pin. Also, be sure to connect a bypass capacitor between V_{CC} and GND for further stabilization of output. (To avoid the noise effect, layout the grounding close to the IC.) Oscillation can occur if capacitance is susceptible to temperature. We recommend using a tantalum electrolytic capacitor with minimal changes in capacitance.

(4) Overcurrent protection circuit

An overcurrent protection circuit is installed in each output system, based on the respective output current. This prevents IC destruction by overcurrent, by limiting the current with a curve shape of "7" in the voltage-current graph. The IC is designed with margins so that current flow will be restricted and latching will be prevented even if a large current suddenly flows through a large capacitor. Note that these protection circuits are only good for preventing damage from sudden accidents. Make sure your design does not cause the protection circuit to operate continuously under transitional conditions (for instance, when output is clamped at $1V_F$ or higher). Note that the circuit ability is negatively correlated with temperature.

(5) Thermal protection circuit

A built-in thermal protection circuit prevents thermal damage to the IC. All outputs are switched OFF when the circuit operates, and revert to the original state when temperature drops to a certain level.

(6) Improving ripple rejection by capacitors

Ripple rejection of the CDP and MAIN outputs can be improved by installing a capacitor that reduces the AC gain.

(7) Malfunction in intense electric fields

Note that bringing the IC into an intense electric field (such as a radio relay station) may result in malfunction.

● Thermal derating curve

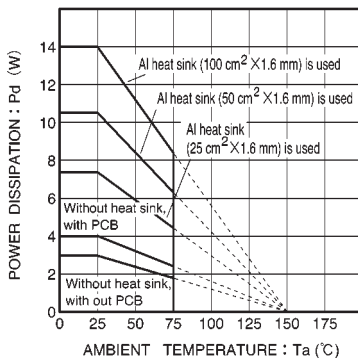

Fig.4

Estimate of allowable power dissipation (P_{MAX})

- Power consumed by CDP $P_1 = (V_{CC} - CDP) \times \text{maximum load current of CDP}$
- Power consumed by μ -COM $P_2 = \{V_{CC} - (\mu\text{-COM})\} \times \text{maximum load current of } \mu\text{-COM}$
- Power consumed by MAIN $P_3 = (V_{CC} - \text{MAIN}) \times \text{maximum load current of MAIN}$
- Power consumed internally by each circuit $P_4 = V_{CC} \times \text{supply current}$

$$P_{MAX.} = P_1 + P_2 + P_3 + P_4$$

● External dimensions (Units: mm)

